

Junior 206 Crate Engine available this fall



Briggs Junior 206

Price: List \$580

Retail ?

Ready to Race: \$580



Comer C-51

Retail - \$700

(Blueprinted) - \$1,100

206 Engine Highlights:

- Cam ground, barrel-faced eutectic alloy piston with chrome-faced top ring set by Federal Mogul
- PVL digital ignition and flywheel system
- Onboard rewind starter
- Factory Ground Cam
- Carbon Steel, reinforced crankshaft
- Dual-ball bearing, I/C sleeved cylinder
- Squeeze-cast, T-7 heat treated racing rod
- Walbro slide carburetor for better throttle control and feel
- Racing 'only' tooling and dies for long-term consistency
- Three-piece automotive style valve spring keepers
- Premium, proprietary materials throughout



KEY ATTRIBUTES

Walbro locking system
to lock & set height

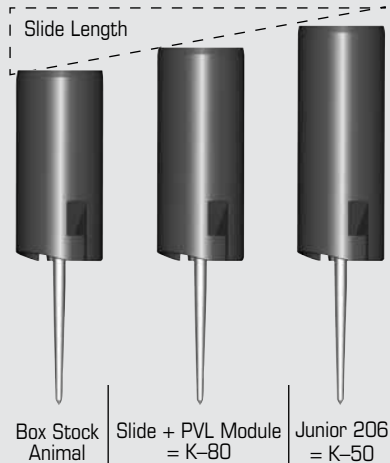
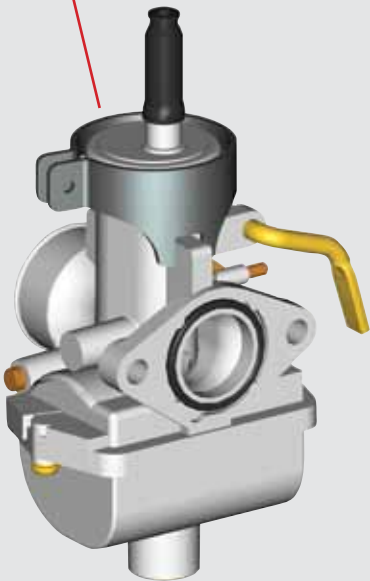

Junior 206 Features:

- Crate Engine – factory custom-sealed bottom-end to control cost
- Hand-built and tested in Milwaukee, WI.
- No maintenance
 - One part number: 555517 Sealed Shortblock, LIST PRICE \$260
 - No resealing agents needed (further promoting a level playing field)
- Modular design for most flexible racing engine configuration
 - Want K-80 power?
 - A simple PVL module/carburetor slide change for under \$100
 - Or you could pay \$1,000 plus for a K-80
- 4-stroke – simple and scalable to any other level of racing
- Level playing field through:
 - PVL digital ignition limited to less than 35 rpm
 - Walbro locking cap and slide (*see illustration*)
 - Simple 'no-go' to control throttle position (bye-bye restrictor plates)
 - Factory installed Ground Cam
 - Factory controlled compression ratio
 - Simple rules, limited tech

BRIGGS & STRATTON



www.Briggsracing.com